



NAYLOR

Spiralweld PIPE SYSTEMS



*The Complete Line of
Spiral Butt weld Pipe and Lockseam Spiralweld Pipe*

Fittings • Flanges • Couplings • Fabrications • Coatings • Linings
Chicago, Illinois • Phone: 773.721.9400 • Fax: 773.721.9494

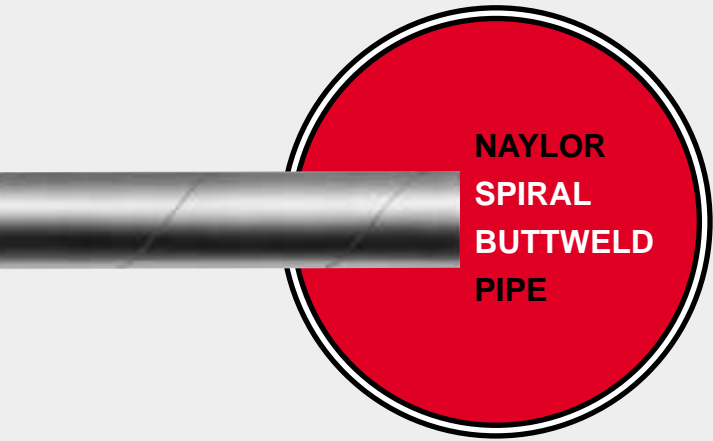

INSPECTION AND TESTING

Every length of Naylor pipe is inspected and where required is tested to the hydrostatic mill test pressure specified in the applicable ASTM specification.

ECONOMY

Naylor Spiral Butt weld Pipe is manufactured in a wide range of wall thicknesses. The fact that this pipe is available in lighter weights than other pipe makes it possible to save money, not only on the initial cost, but also in transportation, handling and installation. It means that by sizing the diameter of the pipe to the exact requirements, with exact lengths and factory-sized ends, the greatest economies can be realized.

Naylor Spiral Butt weld Pipe is manufactured in accordance with ASTM A-139; ASTM A-252, and AWWA C200. It is made from steel strip on automatic equipment designed by Naylor that forms, sizes and completes the manufacture; first, by a sound initial penetrating weld, then followed by a second weld along the outside spiral seam. Each length of completed Naylor Spiral Butt weld Pipe is carefully inspected, and where service conditions require, a hydrostatic test is given to ASTM requirements as shown on pages 3, 4 and 5.

Naylor Spiral Butt weld Pipe is produced in a number of grades of steel to give users a choice of piping to meet their specific needs. From this selection of steels, a complete system can be developed for handling such diverse applications as abrasion-resistant service, corrosion-resistant piping, construction purposes and general industrial uses. In addition to the steels shown, other alloys can be furnished to meet your service requirements. If a size is required that is not listed, it can be made to your order. Standard sizes and wall thicknesses are shown on pages 3, 4 and 5.

EXACT LENGTHS

Naylor Spiral Butt weld can be furnished in industrial standard lengths of 20'0"; line pipe standard lengths of 40'0", 50'0" and 60'0"; and structural lengths up to 100'0". All piping can be cut to any required length to tolerance of plus-or-minus 1/8".

STRUCTURAL STRENGTH

Naylor Spiral Butt weld Pipe features two welds along the spiral seam. This creates a pipe structure in which the weld is as strong or stronger than the parent metal.

UNIFORM WALL

Because thickness tolerances of steel strip are governed by the standards established by the American Iron and Steel Institute, uniform wall thicknesses are assured. This minimizes irregularities which could cause uneven wear.

ACCURATE DIAMETER

The Naylor manufacturing process creates a pipe that maintains an accurate diameter throughout its length. The uniformity of the pipe ends speeds connections, whether mechanically coupled or welded.

STEEL ANALYSES

Naylor Spiral Butt weld Pipe is offered as standard in grades of steel as shown. Variations from these analyses are also available to meet your specific applications.

BASIC CARBON STEEL (ASTM A-139)

Carbon	.30 Max.
Manganese	1.0 Max.
Phosphorus	.035 Max.
Sulphur	.035 Max.

ABRASION-RESISTANT STEEL

Carbon	.30-.35
Manganese	1.00-1.50
Phosphorus.	.008-.025
Sulphur	.020-.035
Silicon	.035 Max.

STRUCTURAL STEEL (ASTM A-252)

Physical Requirements	Grade 2	Grade 3
Tensile Strength Min.	60,000 p.s.i.	66,000 p.s.i.
Yield Point Min.	35,000 p.s.i.	45,000 p.s.i.

WEATHERING STEEL (ASTM A-588)

OTHER STEELS AVAILABLE

Naylor also offers steel grades suitable for your specific applications, including copper bearing, low-alloy high strength steels, as well as grades alloyed to meet your exact requirements.

NAYLOR PIPE

**FOR OVER 75 YEARS, WE HAVE BEEN
AVAILABLE TO MEET YOUR NEEDS
WITH TOP QUALITY PRODUCTS AND
ON TIME SHIPMENTS OF
SPIRALWELD PIPE SYSTEMS.**

STANDARD SPECIFICATIONS

NAYLOR SPIRAL BUTTWELD PIPE

Size Inches	Wall Thickness Inches	Weight of Pipe Lbs./Ft.	INTERNAL PRESSURE			
			Working Pressure P.S.I. S=15,000	Minimum Mill Test P.S.I. ①		Approx. Bursting Pressure P.S.I. S=60,000
				Grade A S=18,000	Grade B S=21,000	
6 O.D.	.134	8.40	701	842	982	2805
	.187	11.62	997	1197	1396	3989
6 I.D.	.134	8.79	670	804	938	2680
	.187	12.37	935	1122	1309	3739
6 ⁵ / ₈ O.D.	.134	9.30	632	759	885	2529
	.187	12.87	897	1077	1256	3590
8 O.D.	.134	11.27	520	624	728	2080
	.187	15.62	736	883	1030	2943
8 I.D.	.134	11.65	503	603	704	2010
	.187	16.37	701	841	982	2805
8 ⁵ / ₈ O.D.	.134	12.16	481	577	673	1924
	.187	16.87	680	816	952	2720
9 O.D.	.134	12.70	460	552	645	1842
	.187	17.62	650	780	911	2601
	.250	23.38	882	1059	1235	3529
9 I.D.	.134	13.08	447	536	625	1787
	.187	18.37	623	748	873	2493
	.250	24.72	833	1000	1167	3333
9 ⁵ / ₈ O.D.	.134	13.60	430	516	601	1718
	.187	18.87	606	728	849	2426
	.250	25.06	822	986	1151	3288
10 O.D.	.134	14.13	413	496	578	1652
	.187	19.62	583	699	816	2331
	.250	26.06	789	947	1105	3158
10 I.D.	.134	14.52	402	482	563	1608
	.187	20.37	561	673	785	2244
	.250	27.39	750	900	1050	3000
10 ³ / ₄ O.D.	.134	15.21	384	460	537	1534
	.179	20.23	517	620	723	2067
	.187	21.12	541	649	757	2163
11 O.D.	.134	15.57	375	449	524	1498
	.179	20.71	505	606	706	2018
	.187	21.62	528	634	739	2112
11 I.D.	.134	15.95	365	439	512	1462
	.179	21.39	488	586	683	1953
	.187	22.37	510	612	714	2040
12 O.D.	.134	17.00	343	411	480	1371
	.179	22.62	461	554	646	1845
	.187	23.61	483	579	676	1930
12 I.D.	.250	31.40	652	783	913	2609
	.312	39.04	824	989	1154	3297

Size Inches	Wall Thickness Inches	Weight of Pipe Lbs./Ft.	INTERNAL PRESSURE			
			Working Pressure P.S.I. S=15,000	Minimum Mill Test P.S.I. ①		Approx. Bursting Pressure P.S.I. S=60,000
				Grade A S=18,000	Grade B S=21,000	
12 I.D.	.134	17.38	335	402	469	1340
	.179	23.30	448	537	627	1790
	.187	24.36	467	561	654	1870
	.250	32.74	625	750	875	2500
12 ³ / ₄ O.D.	.134	18.07	322	386	451	1288
	.179	24.06	433	520	607	1733
	.187	25.11	453	544	635	1813
	.250	33.41	612	735	857	2449
14 O.D.	.134	19.86	293	351	410	1171
	.187	27.61	412	494	576	1647
	.250	36.75	556	667	778	2222
	.312	45.73	701	841	981	2804
14 I.D.	.134	20.25	287	345	402	1149
	.187	28.36	401	481	561	1603
	.250	38.08	536	643	750	2143
	.312	47.81	670	804	938	2679
16 O.D.	.134	22.73	256	307	358	1022
	.187	31.61	359	431	503	1436
	.250	42.09	484	581	677	1935
	.312	52.41	610	732	854	2439
16 I.D.	.134	23.11	251	302	352	1005
	.187	32.36	351	421	491	1402
	.250	43.43	469	563	656	1875
	.312	54.49	586	703	820	2344
18 O.D.	.134	25.59	227	272	317	907
	.187	35.61	318	382	446	1273
	.250	47.44	429	514	600	1714
	.312	59.09	540	647	755	2158
18 I.D.	.134	25.98	223	268	313	893
	.187	36.36	312	374	436	1247
	.250	48.77	417	500	583	1667
	.312	61.18	521	625	729	2083
20 O.D.	.134	28.46	204	244	285	815
	.187	39.61	286	343	400	1143
	.250	52.78	385	462	538	1538
	.312	65.77	484	581	677	1935
20 I.D.	.134	28.84	201	241	281	804
	.187	40.36	280	337	393	1122
	.250	54.12	375	450	525	1500
	.312	67.86	469	563	656	1875
20 O.D.	.375	81.68	563	675	788	2250

① Mill Test Pressure 60% of Sy in accordance with ASTM: A-139.

STANDARD SPECIFICATIONS

NAYLOR SPIRAL BUTTWELD PIPE

Size Inches	Wall Thickness Inches	Weight of Pipe Lbs./Ft.	INTERNAL PRESSURE			
			Working Pressure P.S.I. S=15,000	Minimum Mill Test P.S.I. ①		Approx. Bursting Pressure P.S.I. S=60,000
				Grade A S=18,000	Grade B S=21,000	
22 O.D.	.134	31.32	185	222	259	740
	.187	43.61	259	311	363	1038
	.250	58.13	349	419	488	1395
	.312	72.45	439	526	614	1754
	.375	86.69	529	635	741	2118
22 I.D.	.134	31.71	183	219	256	731
	.187	44.36	255	306	357	1020
	.250	59.46	341	409	477	1364
	.312	74.54	426	511	597	1705
	.375	89.70	511	614	716	2045
24 O.D.	.134	34.19	169	203	237	678
	.187	47.60	237	285	332	950
	.250	63.47	319	383	447	1277
	.312	79.13	401	481	561	1604
	.375	94.71	484	581	677	1935
24 I.D.	.134	34.57	168	201	235	670
	.187	48.35	234	280	327	935
	.250	64.81	313	375	438	1250
	.312	81.22	391	469	547	1563
	.375	97.71	469	563	656	1875
26 O.D.	.134	37.05	156	187	219	625
	.187	51.60	219	263	306	876
	.250	68.82	294	353	412	1176
	.312	85.81	369	443	517	1478
	.375	102.73	446	535	624	1782
26 I.D.	.134	37.44	155	186	216	618
	.187	52.35	216	259	302	863
	.250	70.15	288	346	404	1154
	.312	87.90	361	433	505	1442
	.375	105.73	433	519	606	1731
28 O.D.	.134	39.92	145	174	203	580
	.187	55.60	203	244	284	812
	.250	74.16	273	327	382	1091
	.312	92.49	342	411	479	1370
	.375	110.74	413	495	578	1651
28 I.D.	.134	40.30	144	172	201	574
	.187	56.35	200	240	280	801
	.250	67.48	300	360	420	1200
	.312	94.58	335	402	469	1339
	.375	113.75	402	482	563	1607
30 O.D.	.134	42.78	135	162	189	541
	.187	59.60	189	227	265	757
	.250	79.51	254	305	356	1017
	.312	99.18	319	383	447	1277
	.375	118.76	385	462	538	1538
30 I.D.	.134	43.10	134	161	188	536
	.187	60.35	187	224	262	748
	.250	80.84	250	300	350	1000
	.312	101.26	313	375	438	1250
	.375	121.77	375	450	525	1500
32 O.D.	.134	45.65	127	152	177	507
	.187	63.60	177	213	248	710
	.250	84.85	238	286	333	952
	.312	105.86	299	359	418	1195
	.375	126.78	360	432	504	1440
32 I.D.	.134	45.65	127	152	177	507
	.187	63.60	177	213	248	710
	.250	84.85	238	286	333	952
	.312	105.86	299	359	418	1195
	.375	126.78	360	432	504	1440
34 O.D.	.134	48.51	119	143	167	477
	.187	67.59	167	200	234	667
	.250	90.20	224	269	313	896
	.312	112.54	281	337	393	1124
	.375	134.80	338	406	474	1353
34 I.D.	.134	48.51	119	143	167	477
	.187	67.59	167	200	234	667
	.250	90.20	224	269	313	896
	.312	112.54	281	337	393	1124
	.375	134.80	338	406	474	1353
36 O.D.	.134	51.38	113	135	158	450
	.187	71.59	157	189	220	630
	.250	95.54	211	254	296	845
	.312	119.22	265	318	371	1060
	.375	142.81	319	383	447	1277
36 I.D.	.134	51.38	113	135	158	450
	.187	71.59	157	189	220	630
	.250	95.54	211	254	296	845
	.312	119.22	265	318	371	1060
	.375	142.81	319	383	447	1277
38 O.D.	.187	75.59	149	179	209	596
	.250	100.89	200	240	280	800
	.312	125.90	251	301	351	1003
	.375	150.83	302	362	423	1208
	.500	200.44	405	486	568	1622
38 I.D.	.187	75.59	149	179	209	596
	.250	100.89	200	240	280	800
	.312	125.90	251	301	351	1003
	.375	150.83	302	362	423	1208
	.500	200.44	405	486	568	1622
40 O.D.	.187	79.59	142	170	198	566
	.250	106.23	190	228	266	759
	.312	132.58	238	286	333	952
	.375	158.85	287	344	401	1146
	.500	211.13	385	462	538	1538
40 I.D.	.187	79.59	142	170	198	566
	.250	106.23	190	228	266	759
	.312	132.58	238	286	333	952
	.375	158.85	287	344	401	1146
	.500	211.13	385	462	538	1538
42 O.D.	.187	83.59	135	162	189	539
	.250	111.58	181	217	253	723
	.312	139.26	227	272	317	906
	.375	166.87	273	327	382	1091
	.500	221.82	366	439	512	1463
42 I.D.	.187	83.59	135	162	189	539
	.250	111.58	181	217	253	723
	.312	139.26	227	272	317	906
	.375	166.87	273	327	382	1091
	.500	221.82	366	439	512	1463
44 O.D.	.187	87.58	129	154	180	514
	.250	116.92	172	207	241	690
	.312	145.95	216	259	303	865
	.375	174.88	260	312	364	1040
	.500	232.51	349	419	488	1395
44 I.D.	.187	87.58	129	154	180	514
	.250	116.92	172	207	241	690
	.312	145.95	216	259	303	865
	.375	174.88	260	312	364	1040
	.500	232.51	349	419	488	1395
46 O.D.	.187	91.58	123	148	172	492
	.250	122.27	165	198	231	659
	.312	152.63	207	248	289	826
	.375	182.90	249	298	348	994
	.500	243.20	333	400	467	1333
46 I.D.	.187	91.58	123	148	172	492
	.250	122.27	165	198	231	659
	.312	152.63	207	248	289	826
	.375	182.90	249	298	348	994
	.500	243.20	333	400	467	1333
48 O.D.	.187	95.58	118	141	165	471
	.250	127.61	158	189	221	632
	.312	159.31	198	237	277	792
	.375	190.92	238	286	333	952
	.500	253.89	319	383	447	1277
48 I.D.	.187	95.58	118	141	165	471
	.250	127.61	158	189	221	632
	.312	159.31	198	237	277	792
	.375	190.92	238	286	333	952
	.500	253.89	319	383	447	1277

Size Inches	Wall Thickness Inches	Weight of Pipe Lbs./Ft.	INTERNAL PRESSURE			
			Working Pressure P.S.I. S=15,000	Minimum Mill Test P.S.I. ①		Approx. Bursting Pressure P.S.I. S=60,000
				Grade A S=18,000	Grade B S=21,000	
30 O.D.	.134	43.10	134	161	188	536
	.187	60.35	187	224	262	748
	.250	80.84	250	300	350	1000
	.312	101.26	313	375	438	1250
	.375	121.77	375	450	525	1500
30 I.D.	.134	43.10	134	161	188	536
	.187	60.35	187	224	262	748
	.250	80.84	250	300	350	1000
	.312	101.26	313	375	438	1250
	.375	121.77	375	450	525	1500
32 O.D.	.134	45.65	127	152	177	507
	.187	63.60	177	213	248	710
	.250	84.85	238	286	333	952
	.312	105.86	299	359	418	1195
	.375	126.78	360	432	504	1440
32 I.D.	.134	45.65	127	152	177	507
	.187	63.60	177	213	248	710
	.250	84.85	238	286	333	952
	.312	105.86	299	359	418	1195
	.375	126.78	360	432	504	1440
34 O.D.	.134	48.51	119	143	167	477
	.187	67.59	167	200	234	667
	.250	90.20	224	269	313	896
	.312	112.54	281	337	393	1124
	.375	134.80	338	406	474	1353
34 I.D.	.134	48.51	119	143	167	477
	.187	67.59	167	200	234	667
	.250	90.20	224	269	313	896
	.312	112.54	281	337	393	1124
	.375	134.80	338	406	474	1353
36 O.D.	.134	51.38	113	135	158	450
	.187	71.59	157	189	220	630
	.250	95.54	211	254	296	845
	.312	119.22	265	318	371	1060
	.375	142.81	319	383	447	1277
36 I.D.	.134	51.38	113	135	158	450
	.187	7				

STANDARD SPECIFICATIONS

NAYLOR SPIRAL BUTTWELD PIPE

Size Inches	Wall Thickness Inches	Weight of Pipe Lbs./Ft.	INTERNAL PRESSURE			
			Working Pressure P.S.I. S=15,000	Minimum Mill Test P.S.I. ①		Approx. Bursting Pressure P.S.I. S=60,000
				Grade A S=18,000	Grade B S=21,000	
50 O.D.	.250	132.96	152	182	212	606
	.312	165.99	190	228	266	759
	.375	198.94	228	274	320	914
	.500	264.58	306	367	429	1224
52 O.D.	.250	138.30	146	175	204	583
	.312	172.67	182	219	255	730
	.375	206.95	220	263	307	878
	.500	275.27	294	353	412	1176
54 O.D.	.250	143.65	140	168	196	561
	.312	179.35	176	211	246	703
	.375	214.97	211	254	296	845
	.500	285.96	283	340	396	1132
56 O.D.	.250	148.99	135	162	189	541
	.312	186.03	169	203	237	677
	.375	222.99	204	244	285	814
	.500	296.65	273	327	382	1091
58 O.D.	.250	154.34	130	157	183	522
	.312	192.71	163	196	229	654
	.375	231.01	197	236	275	786
	.500	307.34	263	316	368	1053
60 O.D.	.250	159.68	126	151	176	504
	.312	199.40	158	189	221	632
	.375	239.03	190	228	266	759
	.500	318.03	254	305	356	1017
62 O.D.	.250	165.03	122	146	171	488
	.312	206.08	153	183	214	611
	.375	247.04	184	220	257	735
	.500	328.72	246	295	344	984
64 O.D.	.250	170.37	118	142	165	472
	.312	212.76	148	178	207	592
	.375	255.06	178	213	249	711
	.500	339.41	238	286	333	952
66 O.D.	.250	175.72	115	137	160	458
	.312	219.44	143	172	201	574
	.375	263.08	172	207	241	690
	.500	350.10	231	277	323	923
68 O.D.	.250	181.06	111	133	156	444
	.312	226.12	139	167	195	557
	.375	271.10	167	201	234	669
	.500	360.79	224	269	313	896
70 O.D.	.250	186.41	108	129	151	432
	.312	232.80	135	162	189	541
	.375	279.11	162	195	227	650
	.500	371.48	217	261	304	870
72 O.D.	.250	191.75	105	126	147	420
	.312	239.48	131	158	184	525
	.375	287.13	158	189	221	632
	.500	382.17	211	254	296	845
74 O.D.	.250	196.91	101	122	143	405
	.312	245.54	126	153	179	506
	.375	294.87	152	184	215	608
	.500	393.16	203	247	288	811

Size Inches	Wall Thickness Inches	Weight of Pipe Lbs./Ft.	INTERNAL PRESSURE			
			Working Pressure P.S.I. S=15,000	Minimum Mill Test P.S.I. ①		Approx. Bursting Pressure P.S.I. S=60,000
				Grade A S=18,000	Grade B S=21,000	
76 O.D.	.250	202.25	99	118	138	395
	.312	252.20	123	148	172	493
	.375	302.95	148	178	207	592
	.500	403.17	197	237	276	789
78 O.D.	.250	207.59	96	115	135	385
	.312	258.87	120	144	168	480
	.375	310.97	144	173	202	577
	.500	413.85	192	231	269	769
80 O.D.	.250	212.93	94	113	131	375
	.312	265.53	117	140	164	468
	.375	318.98	141	169	197	563
	.500	424.53	188	225	263	750
82 O.D.	.312	272.20	114	137	160	457
	.375	326.99	137	165	192	549
	.500	435.21	183	220	256	732
	84 O.D.	.312	278.86	111	134	156
.375		335.00	134	161	188	536
.500		445.89	179	214	250	714
86 O.D.		.312	285.53	109	131	152
	.375	343.01	131	157	183	523
	.500	456.57	174	209	244	698
	88 O.D.	.312	292.19	106	128	149
.375		351.03	128	153	179	511
.500		467.25	170	205	239	682
90 O.D.		.312	298.85	104	125	146
	.375	359.04	125	150	175	500
	.500	477.93	167	200	233	667
	92 O.D.	.312	305.52	102	122	142
.375		367.05	122	147	171	489
.500		488.61	163	196	228	652
94 O.D.		.312	312.18	100	119	139
	.375	375.31	120	144	168	479
	.500	499.29	160	191	223	638
	96 O.D.	.312	318.85	98	117	137
.375		383.07	117	141	164	469
.500		509.97	156	188	219	625

Notes:

Please call for diameters and wall thicknesses other than those shown.

Collapse pressures and recommended span data available on request.

All pressures in pounds per square inch.

Above 40" diameter, certain test pressures are reduced in heavy wall thickness to conform with testing equipment capacity.

① Mill Test Pressure 60% of Sy in accordance with ASTM: A-139.

NAYLOR PIPE PILING

**Your direct call to Naylor's Chicago plant
will give you personalized service including:**

- Competitive Pricing
- 100% domestic steel
- Exact lengths
- Attached or loose end plates
- Conical points, chill & splice rings as required
- In-plant inspection
- Certification with the shipment
- Prompt availability and on time delivery of test and production pile

NAYLOR STANDARD PILING SIZES											
(Weights per foot in pounds)											
WALL THICKNESS											
Inches	0.179	0.188	0.203	0.209	0.219	0.230	0.250	0.281	0.312	0.375	
mm	4.55	4.78	5.66	5.31	5.56	5.84	6.35	7.14	7.92	9.53	
10" 254mm	18.8	19.7	21.2	21.9	22.9	24.0	26.0	N/A	N/A	N/A	
10¾" 273mm	20.2	21.2	22.9	23.5	24.6	25.8	28.0	N/A	N/A	N/A	
12" 305mm	22.6	23.7	25.6	26.3	27.6	28.9	31.4	35.2	38.9	N/A	
12¾" 324mm	24.0	25.2	27.2	28.0	29.3	30.8	33.4	37.4	41.4	49.6	
14" 356mm	26.4	27.7	29.9	30.8	32.2	33.8	36.7	41.2	45.6	54.6	
16" 406mm	30.2	31.7	34.2	35.2	36.9	38.7	42.1	47.2	52.3	62.6	
18" 457mm	34.1	35.8	38.6	39.7	41.6	43.7	47.4	53.2	58.9	70.6	
20" 508mm	37.9	39.8	42.9	44.2	46.3	48.6	52.7	59.2	65.6	78.6	

**DIAMETER
OUTSIDER**

Other sizes and wall thicknesses are available upon request.



NAYLOR PIPE

...SINCE 1925

**While other pipe manufacturers have come and gone,
Naylor continues to grow and prosper, concentrating on what it does best...
the manufacture of spiralweld pipe.**

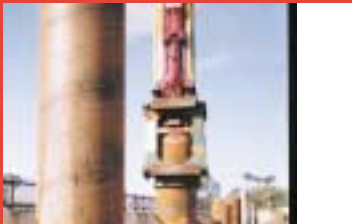

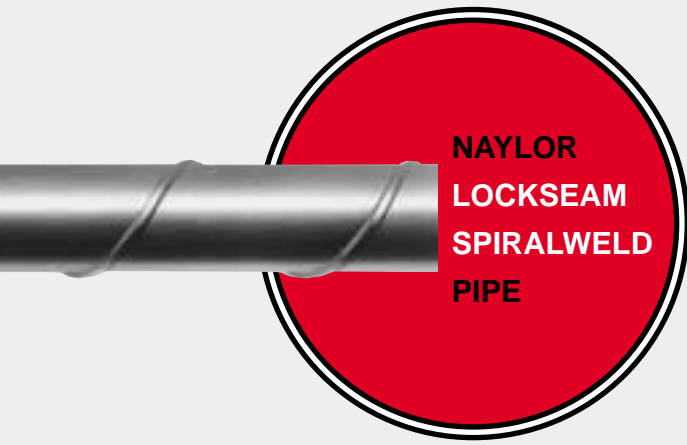

Naylor Lockseam Spiralweld steel pipe is manufactured in strict accordance with ASTM A-211. The standards set forth in this specification are closely adhered to in every phase of production. Quality control is maintained by careful inspection throughout. This is your assurance that Naylor pipe equals or exceeds the ASTM specification in every respect.

EXCLUSIVE STRUCTURE

Naylor Lockseam Spiralweld Pipe is formed from strip which is lockseamed over an internal mandrel. This process creates an accurate tubular structure before it is welded. Thus, the lockseam carries the load and relieves the weld of stresses encountered when the pipe is in service. After the lockseaming operation, the pipe is welded by completely automatic methods which insure a weld that is as strong as the parent metal. Every length of Naylor Lockseam Spiralweld Pipe is inspected and tested to the hydrostatic mill test pressures shown in the tables on the opposite page.

STRENGTH

Naylor Lockseam Spiralweld Pipe provides greater overall strength than other steel pipe of the same wall thickness--under crushing loads, compression, collapse, and beam load at supports. This greater strength--combined with the ability of the lockseam spiralweld to absorb shock loads, stresses and strains--makes it possible for Naylor Lockseam Spiralweld Pipe to handle jobs normally requiring heavier-wall pipe.

SAFETY

Naylor Lockseam Spiralweld Pipe incorporates a safety factor found in no other pipe. When strains are put on the line, the "heel" of the lockseam moves minutely, shortening or lengthening the pipe. Because the "heel" is in spiral form, it acts as a continuous expansion joint throughout the line. It absorbs shock loads and vibration, often destructive to a weld on a rigid structure. It cushions expansion and contraction under varying changes of pressure, temperature and ground stress. It protects both pipe and coupling medium. This factor of "give" is of major importance in pipe line construction because it assures closer conformity to topographical conditions without any sacrifice of strength.

ACCURATE DIAMETER

Naylor Lockseam Spiralweld Pipe is formed under tension on a lathe-turned mandrel, which assures a perfectly-round pipe of accurate diameter. The lockseam structure provides reinforced strength to preserve the original true cylindrical form in transportation, installation and service. With ends that always match correctly and this adherence to accurate diameter, Naylor Lockseam Spiralweld Pipe reduces the time required to make connections, whether mechanically coupled or welded.

UNIFORM WALL THICKNESS

Naylor pipe is manufactured from strip or sheet steel which assures uniform wall thickness. Thickness tolerances are governed by the standards established by the American Iron and Steel Institute.

EXACT LENGTHS

Naylor Lockseam Spiralweld Pipe can be furnished in any desired cut length up to and including 40'0". While standard lengths are 20'0", 30'0" or 40'0", the piping can be cut to any required length, to tolerance of plus-or-minus 1/8".

STANDARD WEIGHT ENDS

Naylor pioneered the development of lightweight pipe combined with standard weight ends. Thus, the advantage of light weight pipe is realized and combined with standard fittings and equipment common to industry.

ECONOMY

Naylor Lockseam Spiralweld Pipe saves time, material and money for users. Its structure permits use on jobs normally requiring heavier-wall pipe. The relatively light weight reduces transportation, handling and installation costs as well as the initial investment. High salvage and re-use value are assured by the accurate diameter and true cylindrical form which results from the lockseam spiralweld structure.



STANDARD SPECIFICATIONS

NAYLOR LOCKSEAM SPIRALWELD PIPE

Inside Diameter Inches	Wall Thickness Decimal Inches	Weight of Pipe lbs./Ft.	Overall Diameter Lockseam	Recommended Max. Span Pipe Filled with Water—Feet ③	Mill Test Pressure P.S.I. Grade A S=20,000 # ①	Working Pressure P.S.I. S=12,500#	Approx. Bursting Pressure P.S.I. S=50,000#	External Collapse Pressure P.S.I. ②
4	.074	3.96	4.5976	16.6	740	467	1866	550.0
5	.074	4.74	5.5976	18.4	592	373	1492	375.0
6	.074	5.57	6.5976	20.0	493	311	1244	248.0
	.104	7.94	6.8368	21.6	693	435	1740	479.0
	.134	10.42	7.0760	22.8	893	562	2248	777.0
8	.074	7.22	8.5976	22.6	370	234	934	142.6
	.104	10.23	8.8368	24.6	520	326	1304	273.7
	.134	13.20	9.0760	26.1	670	422	1688	445.4
10	.074	9.00	10.5976	24.8	296	187	746	91.9
	.104	12.74	10.8368	27.0	416	261	1042	176.8
	.134	16.45	11.0760	28.8	536	337	1348	287.3
	.164	20.40	11.3152	30.1	656	412	1646	428.4
12	.074	10.72	12.5976	26.6	247	156	622	71.6
	.104	14.85	12.8368	29.2	347	217	868	124.4
	.134	19.10	13.0760	31.2	447	282	1126	200.6
	.164	23.90	13.3152	32.8	547	343	1372	299.2
13 1/4	.074	11.82	13.8476	25.6	223	141	564	56.8
	.104	16.39	14.0868	30.4	314	197	788	102.5
	.134	21.08	14.3260	32.5	405	255	1018	167.9
	.164	26.35	14.5652	34.2	495	311	1242	248.2
14	.074	12.50	14.5976	24.6	211	134	534	49.8
	.104	17.31	14.8368	31.1	297	186	744	91.9
	.134	22.25	15.0760	33.3	383	241	964	150.7
	.164	27.82	15.3152	35.0	469	294	1176	219.3
15 1/4	.074	13.74	15.8476	22.6	194	123	490	40.9
	.104	19.03	16.0868	32.2	273	171	684	77.5
	.134	24.21	16.3260	34.4	351	222	886	127.3
	.164	30.28	16.5652	36.2	430	270	1080	187.0
16	.074	14.42	16.5976	21.3	185	117	466	36.4
	.104	19.96	16.8368	32.5	260	163	652	70.7
	.134	25.41	17.0760	35.2	335	211	844	115.9
	.164	31.75	17.3152	37.0	410	258	1030	170.0
17 1/4	.074	15.68	17.8476	18.9	172	108	432	30.5
	.104	21.51	18.0868	30.6	241	151	604	60.8
	.134	27.37	18.3260	36.2	311	196	782	99.9
	.164	34.19	18.5652	38.2	380	239	954	148.5
18	.074	16.35	18.5976	18.3	164	105	420	27.6
	.104	22.43	18.8368	29.5	231	145	580	55.9
	.134	28.55	19.0760	36.9	298	188	750	91.9
	.164	35.66	19.3152	38.9	364	229	914	136.3
19 1/4	.074	17.50	19.8476	16.8	154	97	388	23.6
	.104	23.98	20.0868	27.9	216	136	542	48.9
	.134	30.52	20.3260	37.1	278	175	700	80.5
	.164	38.12	20.5652	40.0	341	214	856	119.5
20	.074	18.17	20.5976	15.7	148	94	374	21.5
	.104	24.91	20.8368	26.5	208	131	522	45.3
	.134	31.69	21.0760	35.9	268	169	676	74.6
	.164	39.60	21.3152	40.5	328	206	822	110.8
21 1/4	.074	19.30	21.8476	14.2	139	88	352	18.7
	.104	26.46	22.0868	24.7	196	123	492	40.2
	.134	33.66	22.3260	34.2	252	159	636	66.2
	.164	42.06	22.5652	41.5	309	194	774	98.4
23 1/8	.074	21.01	23.7226	12.4	128	81	324	15.3
	.104	28.78	23.9618	22.1	179	113	452	33.8
	.134	36.61	24.2010	31.6	231	146	584	55.9
	.164	45.74	24.4402	39.7	283	178	712	83.3
24	.074	21.80	24.5976	11.5	123	78	312	14.0
	.104	29.87	24.8368	21.0	173	109	434	31.0
	.134	37.99	25.0760	30.3	223	141	562	52.0
	.164	47.44	25.3152	38.6	273	172	686	77.3
26	.074	23.59	26.5976	9.9	114	72	288	11.5
	.104	32.34	26.8368	18.6	160	101	402	25.7
	.134	41.14	27.0760	27.4	206	130	518	44.5
	.164	51.37	27.3152	36.1	252	159	634	66.1
28	.074	25.42	28.5976	8.6	106	67	268	9.7
	.104	34.81	28.8368	16.5	149	94	374	21.6
	.134	44.28	29.0760	25.2	191	121	481	38.2
	.164	55.30	29.3152	33.4	234	147	588	57.1
30	.074	27.23	30.5976	7.5	99	62	248	8.2
	.104	37.29	30.8368	14.6	138	87	348	18.3
	.134	47.23	31.0760	22.8	179	113	450	33.1
	.164	59.23	31.3152	30.9	218	138	550	49.8



STEEL ANALYSES

Unless otherwise specified, Naylor Lockseam Spiralweld Pipe is furnished in basic carbon steel. For application where a high strength steel with superior abrasion and corrosion resistance is desirable, this pipe is available in stainless steel to meet specific requirements. The following are typical analyses of materials.

BASIC CARBON STEEL (ASTM A-570)

Carbon08-.25
Manganese30-.90
Phosphorus04 Max.
Sulphur04 Max.
Silicon10 Max.

STAINLESS STEEL

Type 304:

Carbon08 Max.
Manganese	2.00 Max.
Silicon	1.00 Max.
Chromium	18.00-20.00
Nickel	8.00-12.00

Type 316:

Carbon08 Max.
Manganese	2.00 Max.
Silicon	1.00 Max.
Chromium	16.00-18.00
Nickel	10.00-14.00
Molybdenum	2.00-3.00

Extra Low Carbon (ELC) grades and other analyses are also available.



① In accord with ASTM 211 using A570 Grade "A" Steel.

② Collapse pressures shown are for 6 pipe diameter lengths. Collapse pressure on longer lengths will be lower.

③ Assume pipe bearing on 120' saddle supports.

NAYLOR

CONVENTIONAL WEDGELOCK COUPLINGS

**Standard One-Piece,
Positive Type Couplings
for Speed,
Simplicity and Economy
of Connection on
Spiral Butt weld and
Lockseam Spiral weld Pipe**

Built in one piece with gasket already in place, Naylor Wedgelock Couplings provide the fastest and easiest way to connect grooved end or shoulder end pipe.

They provide a simple yet positive connection that is anchored to the end of the pipe and will not allow the line to separate or pull apart. A hammer is the only tool required to connect or disconnect them. A joint can be made up with only one side of the pipeline in the open. Since the Wedgelock takes up little more

space than the diameter of the pipe itself, the line can hug the wall in tunnels, mines, or wherever space is limited.

Wedgelock Couplings are designed to provide a small degree of deflection in each joint. This design allows for expansion and contraction, and replacement of joints can be made at any point without disturbing the balance of the line. The couplings also permit a number of lengths to be rotated, when desired, without disturbing the balance of the line.

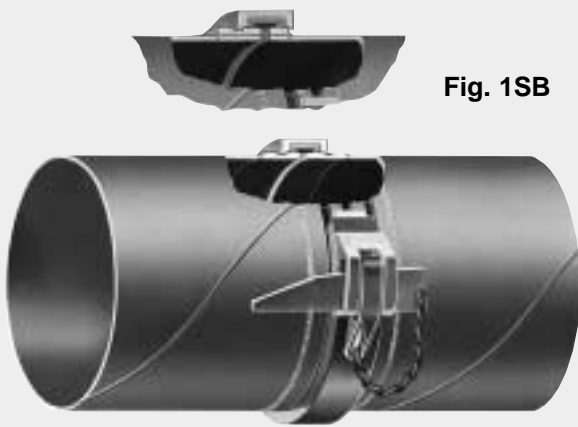

Fig. 1SB

HEAVY DUTY WEDGELOCK COUPLING

The Naylor Heavy Duty Wedgelock Coupling was designed for use with both Naylor Lockseam and Spiral Butt weld Piping Systems. This coupling, when used with exact Naylor sized ends, enables you to select the proper combination of diameter and wall thickness to fit your exact requirements.

Use of this coupling is well-suited on such applications as hydraulicking, water supply lines, dredging, sludge lines and air lines. Figure 1 shows the standard accurately-sized Naylor grooved ends butt welded to the pipe.

Figure 1SB shows the slip-over type end which is preferred for use in abrasive service where the pipe is subject to excessive wear. The slip-over end can be a standard grooved end or the less expensive band type end as illustrated.

Fig. 1

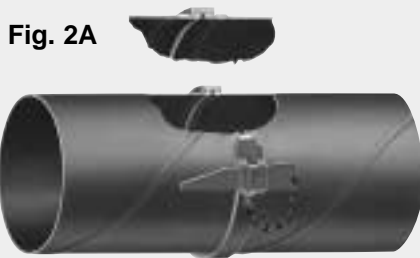

Fig. 2A

Fig. 2

LOW PRESSURE WEDGELOCK COUPLING

Naylor offers the Low-pressure Wedgelock Coupling to meet the need for a fast, positive type coupling method in ventilating lines and similar low-pressure service on either lockseam spiralweld or spiral butt weld pipe. Figure 2 shows the 3/8" Square Shoulder End which is the conventional end preparation for the Low-pressure Wedgelock Coupling. Figure 2A shows the alternate grooved end.

FOUR SIMPLE STEPS SPEED CONNECTIONS WITH STANDARD WEDGELOCK COUPLINGS

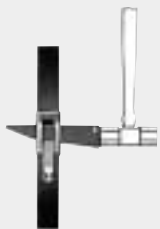

1 To open one-piece coupling, drive wedge into two parallel lugs.

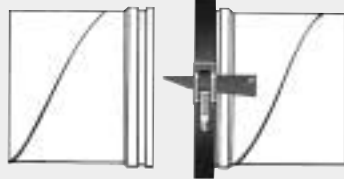

2 Slip coupling over pipe and put next section of pipe in place.

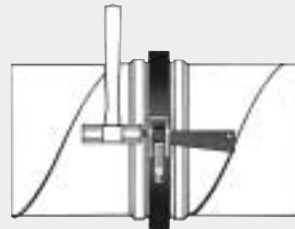

3 Drive out opening wedge so coupling snaps into place on grooved ends of pipe.

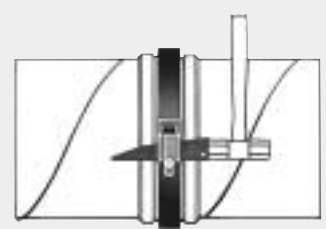

4 Drive wedge home into the three lugs on coupling. Nothing so simple...nothing so fast.

NAYLOR

HINGED WEDGELOCK COUPLINGS



Fig. 1H



HINGED HEAVY-DUTY WEDGELOCK COUPLING

The Naylor Heavy-Duty Hinged Wedgelock Coupling shown in Figure 1H is a variation of the Naylor standard one-piece heavy-duty coupling and offers additional advantages for both permanent and temporary lines. While retaining the simplicity and speed of the standard Wedgelock, the hinged coupling introduces greater flexibility to broaden the use of this versatile connection. The continuous ring gasket provides the seal to withstand the stresses and strains of expansion and contraction in prolonged service. The hinged design and ease of operation offer users the opportunity to replace uniform pipe lengths and/or rotate a number of lengths without disturbing the balance of the line.



Fig. 2H

HINGED INTERMEDIATE PRESSURE WEDGELOCK VENTILATING COUPLING

For use with Naylor Spiral Butt-weld ventilating lines, this variation of the Naylor Hinged Wedgelock Coupling meets the requirements for an inexpensive yet air-tight connector. This quick-connecting and versatile coupling is available in sizes to 72". The multiple hinge design with a one-piece ring gasket provides the leak-tight positive connection.

HINGED HIGH PRESSURE WEDGELOCK COUPLING

The Naylor Extra-Heavy-Duty Hinged Wedgelock Coupling is similar to Figure 1H and is designed to accommodate higher pressure applications and provide an efficient coupling for larger diameter lines. Accurately sized ends and gaskets, combined with a heavier cross section coupling channel extend the size and pressure range of this effective, economical connector.

EASY-TO-INSTALL HINGED WEDGELOCK COUPLINGS

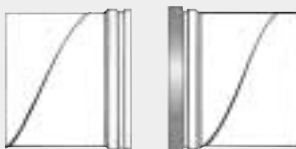

1 Lubricate pipe ends with water soluble lubricant and slide gasket over one pipe end.



2 Bring pipe sections together and slide gasket over the joint. Lubricate outside of gasket with water soluble lubricant.



3 Fit housing over gasket and close coupling into grooved ends of pipe.

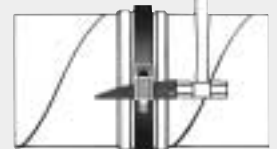

4 Insert wedge into the three lugs on coupling and drive it home with a hammer.

NAYLOR PIPE

ADDITIONAL CONNECTIONS



PLAIN END FOR LOWER COST CONSTRUCTION

Naylor Spiral Butt weld and Lockseam Spiral weld Pipe can be furnished with plain, square-cut ends for field butt welding. The Naylor structure provides accurate diameter, preserves true cylindrical form and, with ends that always match correctly, makes possible the welding of plain-end pipe.



PLAIN END WITH BACK-UP RING

To facilitate field welding of plain-end pipe, a back-up ring can be supplied.

NAYLOR STEEL FLANGED JOINTS

Naylor steel flanges are designed to slip over the ends of spiral butt weld or lockseam spiral weld pipe for welding. They can be furnished drilled to American Standard (125 lb.), to the Spiral Pipe Standard (SPS), or drilled to meet special requirements.

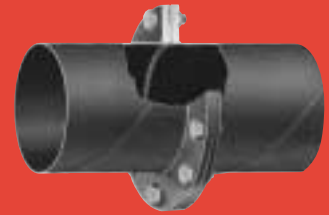

“VICTAULIC” TYPE COUPLINGS

Standard weight grooved ends, made to steel pipe specifications of the Victaulic Company of America, are furnished to permit use of this type of coupling on both spiral butt weld and lockseam spiral weld pipe. Simple and easily connected, this joint provides some flexibility and allowance for expansion and contraction. It will not allow the line to blow apart as the coupling is anchored in the groove.

“DRESSER” TYPE COUPLINGS

Naylor Spiral Butt weld Pipe dimensions are accurately controlled so that tolerances are well within those set by Dresser Manufacturing Company. The outside weld bead on the pipe is ground smooth for a suitable distance to enable the Dresser coupling to properly seat on the plain end pipe. This coupling will take up considerable expansion and contraction, and permit some flexibility at each joint. On exposed lines subject to temperature variations, it is often necessary to provide harnesses to prevent the coupling from working itself off the line.

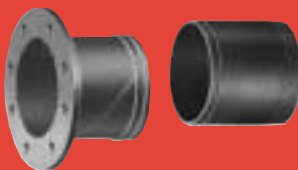

SHORT NIPPLES OR ADAPTORS

Naylor short nipples or adaptors for spiral butt weld or lockseam spiral weld pipe are standardized at one foot in length, but can be furnished longer or shorter. Practically any combination can be made, permitting coupling of any type to be changed to another. Illustrations show flange-to-groove and groove-to-thread. Other units are available to transpose to any connection in this section, or special connections where required.

DREDGING SHORE PIPE JOINT

A standard connection for dredging shore pipe using taper band and lug type construction. The Naylor taper is accurately shrunk to size either from cylindrical stock or directly on plain end pipe. This thickens the small end of the taper where most wear occurs. On the female end, the reinforcing band is set back slightly from the end to allow a slight flaring action which improves the seal. Lugs are ample in weight and size with plenty of hand room. This connection can be used with either spiral butt weld or lockseam spiral weld pipe.



PONTOON PIPE JOINT FOR RUBBER SLEEVE CONNECTION

Conventional half-oval band type pontoon pipe joint. These half-ovals are accurately sized and fit close to the wall of the pipe. The outside weld bead on the spiral butt weld pipe is ground smooth a sufficient distance to allow the rubber sleeve to fit snug against the pipe wall. Upper illustration shows an alternate type construction using slip-over grooved ends for retaining the rubber sleeves. This permits the use of Naylor Heavy-Duty Wedgelock couplings in the line where rubber sleeves are not required at every joint for flexibility. Cost is reduced because the Wedgelock is less expensive and operating efficiency is improved by reducing the friction loss.

STANDARD NAYLOR FITTINGS

Standard Naylor fittings are available in carbon steel, alloys and stainless steel in wall thicknesses to exactly match Naylor pipe sizes. Extra heavy, special radius or combination of fabricated fittings are available.

The plain ends can be prepared to accommodate all standard type end connections to include: (1) slip-on welding flanges; (2) welding rings, collars, slip joints or heavy beveled ends; *(3) standard weight ends grooved for Naylor Wedgelock couplings or other positive type couplings; *(4) standard weight ends smooth for mechanical couplings.

The tables show dimensional specifications for standard Naylor fittings used with pipe having plain or flanged ends.

*Note: If heavy reinforced grooved ends are attached, add the length of the end to the standard dimension shown.

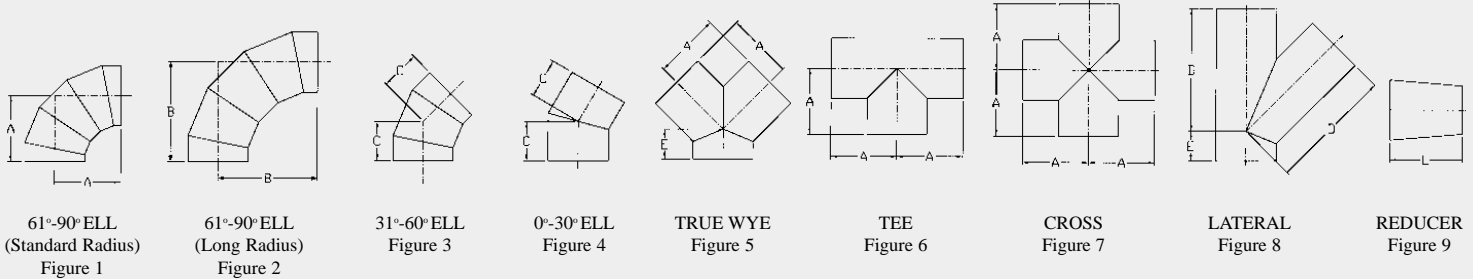

NAYLOR STANDARD DIMENSIONS

Size in Inches	3	4	5	6	8	10	12	14	16	18	20	22	24	26	28	30	32	34	36	38	40	42	48	54	60	66	72
"A"	5½	6½	7½	8	9	11	12	14	15	16½	18	20	22	23	24	25	26	27	28	29	30	31	34	39	44	48	53
"B"	7½	9	10½	11½	14	16½	19	21½	24	26½	29	31½	34	36½	39	41½	44	46½	49	51½	54	56½	64	71½	79	86½	94
"C"	3	4	4½	5	5½	6½	7½	7½	8	8½	9½	10	11	13	14	15	16	17	18	19	20	21	24	27	30	33	36
"D"	10	12	13½	14½	17½	20½	24½	27	30	32	35	37½	40½	44	46½	49	52	56	60	63	66	69	75	80	88	95	104
"E"	3	3	3½	3½	4½	5	5½	6	6½	7	8	8½	9	9	9½	10	14	19	24	24½	25½	26	26	26	26	28	28
"L"	6	7	8	9	11	12	14	16	18	19	20	22	24	24	24	24	24	24	24	24	24	24	24	24	24	24	24

WELDING FITTING STANDARD DIMENSIONS

Size in Inches	3	4	5	6	8	10	12	14	16	18	20	22	24	26	28	30	32	34	36	38	40	42	48	54	60	66	72
"A"	3	4	5	6	8	10	12	14	16	18	20	22	24	26	28	30	32	34	36	38	40	42	48	54	60	66	72
"B"	4½	6	7½	9	12	15	18	21	24	27	30	33	36	39	42	45	48	51	54	57	60	63	72	81	90	99	108
"C"	2	2½	3	3½	5	6½	7½	8½	10	11½	12½	13½	15	16	17½	18½	20	21	22½	23½	25	26	30	33½	37	41	45
"D"	10	12	13½	14½	17½	20½	24½	27	30	32	35	37½	40½	44	46½	49	52	56	60	63	66	69	75	80	88	95	104
"E"	3	3	3½	3½	4½	5	5½	6	6½	7	8	8½	9	9	9½	10	14	19	24	24½	25½	26	26	26	26	28	28
"L"	6	7	8	9	11	12	14	16	18	19	20	22	24	24	24	24	24	24	24	24	24	24	24	24	24	24	24

Note: For sizes not listed, contact Naylor Pipe Company.

NAYLOR SLIP-ON WELDING FLANGES

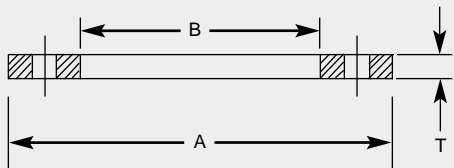

Slip-on flanges for Naylor pipe are carried in stock as shown below. Special drillings or bores are available on request. Flanges can be attached to pipe by Naylor or furnished loose for field installation. When attached by Naylor, the flanges are completely welded, front and back. The bolt holes will straddle normal center lines unless otherwise specified.

ASME PLATE STEEL—Drilled 125 Pound American Standard

Size in Inches	3	4	5	6	8	10	12	14	16	18	20	22	24	26	28	30	36	42	48	54	60	66	72
O.D. "A"	7½	9	10	11	13½	16	19	21	23½	25	27½	29½	32	34½	36½	38½	46	53	59½	66½	73	80	86½
I.D. "B"	BORE TO SUIT EXACT DIAMETER OF PIPE																						
Thickness "T"	½	½	¾	¾	¾	1¼	1¼	¾	¾	¾	¾	1	1	1	1	1	1¼	1¼	1¼	1¼	1½	1½	1½
No. Holes	4	8	8	8	8	12	12	12	16	16	20	20	20	24	28	28	32	36	44	44	52	52	60
Dia. Holes	¾	¾	¾	¾	¾	1	1	1¼	1¼	1¼	1¼	1¼	1¼	1¼	1¼	1¼	1¼	1¼	1¼	1¼	1¼	1¼	1¼
Bolt Circle	6	7½	8½	9½	11¼	14¼	17	18½	21¼	22¼	25	27¼	29½	31¼	34	36	42¼	49½	56	62¼	69¼	76	82¼

Note: Forged, Spiral Pipe Standard (SPS), special drilling, angle and sizes not listed are available.

NAYLOR SPIRALWELD PIPE APPLICATIONS

CONSTRUCTION

Temporary or permanent lines for high and low-pressure air; high and low-pressure water; ventilating lines; cement placing; hydraulic sluicing; de-watering and drainage; well-point headers; exhaust and intake; foundation piling; caissons and tank supports.

MINING AND QUARRYING

Water pipe; high and low-pressure air lines; ventilating pipe; tailings or slurry pipe lines; sand, gravel and other product lines.

DREDGING

Available in abrasion resistant steel. Shore pipe; pontoon pipe; intake and discharge pipe; sand and gravel conveying lines. All types of dredging connections.

MATERIALS HANDLING

Sand, gravel, product and material handling lines; wash water lines; slurry and tailings pipe; rubber-lined pipe; sludge lines; fly ash disposal pipe; pneumatic conveyors.

POLLUTION CONTROL

Filtration plant piping; waste water lines; air purification pipe; sludge disposal systems.

SEWAGE DISPOSAL

Force mains, sludge lines; disposal plant aeration piping; siphons; temporary sewer by-pass lines.

PAPER MILLS

Stock lines; pulp lines; vacuum lines; white water lines; hot and cold water lines; condensate lines; ventilating pipe; exhaust steam; compressed air lines; pneumatic conveying lines; bark, chips and trim disposal.

AGRICULTURE

Surface and underground main lines for irrigation; water-well casing; water supply and de-watering.

INDUSTRIAL PLANTS

High and low-pressure air; water supply; ventilating lines; gas piping and manifolds; diesel exhaust and in-take, low-pressure steam lines; cooling tower piping, drainage lines; spray pond piping; bridge crossings.

PRODUCT COMPONENTS

Pipe sections furnished as component parts of manufactured products; such as portable grain conveyors, tanks, containers, manifolds, and structural members.

FABRICATIONS

Standard fittings and all types of connections are available from stock for standard piping layouts. Precision fabrications to meet specifications for special or complex layouts are available.



NAYLOR PIPE ORDERING GUIDE

NAYLOR SPIRAL BUTTWELD PIPE (ASTM A-139)

Sizes:

6" to 96" in diameter

Thicknesses:

10 gauge (.134) to 1/2" (.500)

Lengths:

Pipe cut to exact specified lengths or 20'0" industrial standard, 40'0", 50'0", 60'0" line pipe standard. Structural piping up to 100'0" long.

NAYLOR LOCKSEAM SPIRALWELD PIPE (ASTM A-211)

Sizes:

4" to 30" in diameter

Thicknesses:

14 gauge (.074) to 8 gauge (.164)

Lengths:

40'0" line pipe standard
20'0" industrial standard
Cut to exact specified lengths



Supplemental Information Required For Ordering Naylor Pipe

Service:

State operating conditions
Material being conveyed
Temperature range
Pressure -- positive or vacuum
Location -- If above ground, state whether suspended or supported. If below ground, give depth and type of fill.

Coatings:

Standard black mill coating
 Outside only or inside and out
Red Iron Oxide
 Outside only or inside and out
Galvanized
Epoxy type coatings
Fusion Bond Epoxy
Other Coatings Available

Fabrications:

All types of pipe and fitting fabrications, regardless of complexity, built to meet exact design specifications.

Linings:

Rubber	Cement
Plastic	Basalt
Synthetic Resin	Ceramic
Epoxy	Polyurethane

Fittings:

A complete line of welded steel fittings, standard or special.
See page 13.

Flanges:

ASME Plate Steel	Special Plates
SPS Plate Steel	Forgings

See page 13.

Connections:

All types of connections available including one-piece positive type Naylor Wedgelock coupling.
See pages 10, 11 and 12.



**The Complete Line Manufacturer of
Spiral Butt weld and Lockseam Spiralweld
Pipe Systems**

Fittings

Flanges

Couplings

Fabrications

Coatings

Linings



NAYLOR PIPE COMPANY

1230 East 92nd Street • Chicago, Illinois 60619

Phone: 773.721.9400 • Fax: 773.721.9494

Visit our Website: www.naylorpipe.com • E-mail: naylor@flash.net